



CAR FILLING



FUEL MANAGEMENT SYSTEMS



KITS



PUMPS



METERS



METERED NOZZLES

SB325_X METER

FEATURES

- HEAVY DUTY
- VERSATILE
- BUILT-IN TURBINE METER
- BREAK-AWAY SYSTEM
- MULTI-FUNCTIONAL DISPLAY

The PIUSI SB325_X METER is the patented automatic metered nozzle by PIUSI for AdBlue®. It is composed by an innovative technopolymer casing, a break-away system, a stainless steel spout and the K24 meter with $\pm 1\%$ accuracy. Safety is guaranteed by the break-away system. In the event that a vehicle accidentally drives away with the nozzle still in the tank, the spout is designed to detach from the nozzle. This system also allows for a quick repair by merely fitting a new spout onto the nozzle.

PERFORMANCE

UP TO

45 L/MIN

FLOW RATE

3,5 BAR

MAX

OPERATING PRESSURE

$\pm 1\%$

ACCURACY



SB325_X METER



PACKAGING

CODE	WEIGHT		PACKAGING		
	KG	LBS	MM	INCH	PCS/BOX
FOO61701A	1,0	2,2	447X178X63	17,6X7X2,5	1



NOZZLES



FILTRATION



TANK MONITORING



HOSE REEL



ACCESSORIES



MERCHANDISE



AIR



ANTIFREEZE



AdBlue®



BIODIESEL



DIESEL



FOOD



GASOLINE



GREASE



KEROSENE



OIL



WATER



WINDSCREEN

CHART

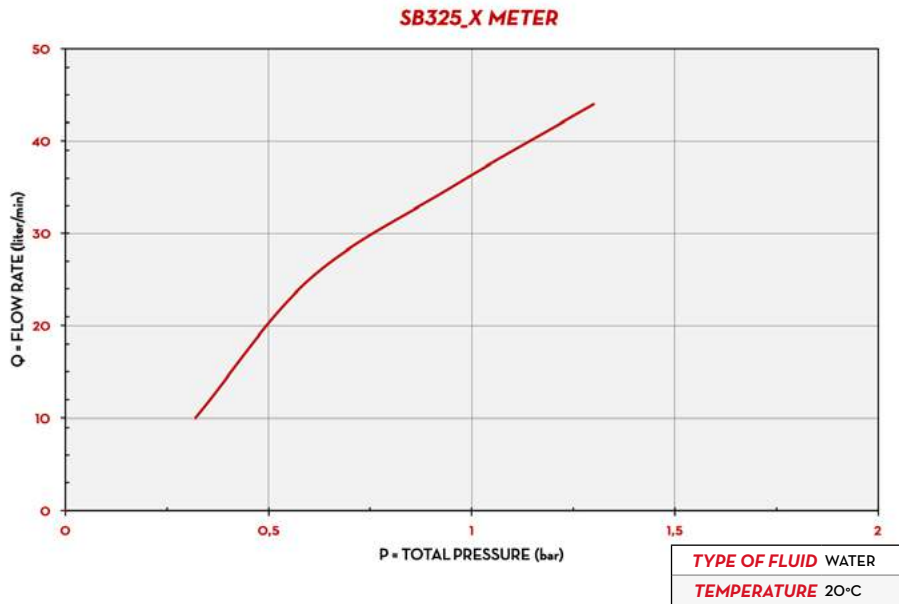

IN THE BOX

- SB325_X METERED NOZZLE
- INSTRUCTION MANUAL

DETAILS



MULTI-FUNCTIONAL DISPLAY



BREAK-AWAY SYSTEM

DIMENSIONS

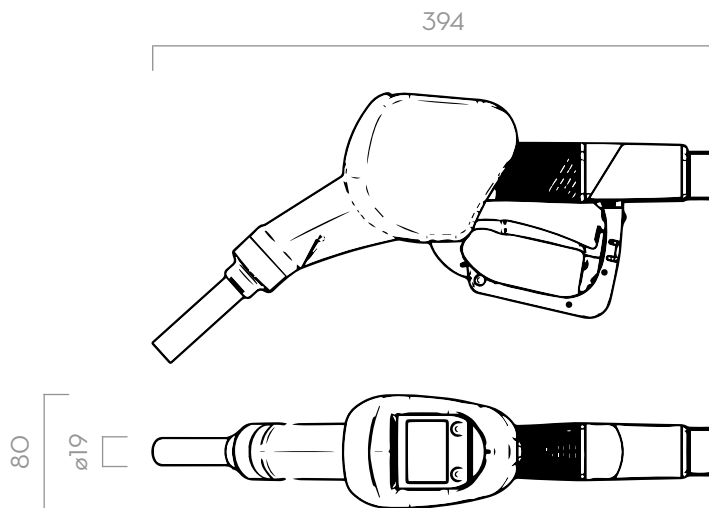

Dimensions expressed in millimeters

MATERIALS

- SPOUT: STAINLESS STEEL
- BODY: TECHNOPYLIMER
- TURBINE: TECHNOPYLIMER

TECHNICAL DATA

CODE	DESCRIPTION	FLUIDS TYPE	FLOW RATE		MAGNETIC ADAPTOR	METER	PRESSURE	INLET	SWIVEL	SPOUT
			L/MIN	GPM			BAR			EXT. Ø
FOO61701A	AUTOMATIC NOZZLE SB325_X METER		45	12	NO	YES	3,5	3/4"	YES	19 MM

SB325_X METER